

Legal Notice of Rulemaking
Nebraska Department of Transportation
Public Hearing
Wednesday, October 21, 2020 - 9:00-11:00 AM
Nebraska Department of Transportation
Central Headquarters Bldg., Rm. 103
1500 Hwy 2, Lincoln, Nebraska



The Nebraska Department of Transportation (NDOT) has commenced rulemaking and will hold a public hearing concerning repealing or revising the following proposed regulations.

17 NAC 1, Public Use Airport/Heliport Licensing

- During an extensive review of all NDOT regulations, it was determined that this regulation would benefit from a revision pertaining to heliports. This includes removing the regulation language for private-use heliports, as the Division's statutory authority to register private-use heliports is questionable.

410 NAC 7, The Accommodation of Mailboxes and Newspaper Delivery Boxes and Support Posts on Highway Rights-Of-Way

- NDOT is transferring this regulation to Title 412 due to a change in ownership within the agency. Because of this action, NDOT is required by law to repeal the chapter and re-adopt the regulation as a new chapter within the new title.

412 NAC 2, The Accommodation of Mailboxes and Newspaper Delivery Boxes and Support Posts on Highway Rights-Of-Way

- NDOT is re-adopting this regulation after repealing it from 410 NAC 7 and updating it to reflect current best practices. These practices include both State and Federal changes that have been implemented since the regulation last received a substantive revision.

414 NAC 1, Nebraska Scenic Byways Program

- NDOT is updating this regulation, originally adopted in 1996, to remove portions of the rule which are no longer applicable.

428 NAC 3, Instruction Manual for Annual Reporting of One- and Six-Year Plans for Highway, Road and Street Improvements

- NDOT is proposing to repeal this regulation in its entirety. The regulation is no longer necessary due to NDOT- and Board-sponsored legislation (LB 82) passed in 2019 by the Legislature. The Legislation requires local political subdivisions to certify to the NBCS their compliance with the law rather than submit the one- and six-year plans to the NBCS for NBCS staff to review. Because of this change in law, 428 NAC 3 is obsolete and unnecessary.

428 NAC 3, Instruction Manual for Standardized System of Annual Reporting Road, Street, and Highway Programs as adopted by the Board of Public Roads Classifications and Standards and approved by the Auditor of Public Accounts

- NDOT is proposing to repeal this regulation in its entirety. The regulation is no longer necessary due to NDOT- and Board-sponsored legislation (LB 82) passed in 2019 by the Legislature. The Legislation requires local political subdivisions to certify to the NBCS their compliance with the law rather than submit the SSAR report to the NBCS for NBCS staff to review. Because of this change in law, 428 NAC 3 is obsolete and unnecessary.

Interested persons are invited to attend the public hearing. Comments and recommendations may be presented orally or in writing at the hearing. They may also be mailed, faxed, or e-mailed prior to the hearing or until the close of the public comment period (October 31, 2020). Pre- and post-hearing comments should be directed in writing to NDOT's External Affairs Manager, Sarah Soula, PO Box 94759, Lincoln, Nebraska 68509-4759; sarah.soula@nebraska.gov; voice telephone (402) 479-4871, TDD telephone (402) 479-3834, fax (402) 479-3989. Comments may also be posted online through the Secretary of State's website (see below).

To view or download the proposed amendments to the regulations or to comment online, visit: <https://www.nebraska.gov/nesos/rules-and-regs/regtrack/index.cgi> ("Agency": Transportation). To obtain a free paper copy of the proposed changes, the Proposed Regulation Policy Pre-Review Checklists, or the Fiscal Impact Statements, contact NDOT's Government Affairs Office, PO Box 94759, Lincoln, Nebraska 68509-4759; voice telephone (402) 479-4324; TDD telephone (402) 479-3834; fax (402) 479-3758; erich.strack@nebraska.gov. To view or pick up copies in person: Director's Office, 1500 Highway 2, Lincoln, NE.

NDOT will make every reasonable accommodation to provide an accessible meeting facility for all persons. Appropriate provisions for the hearing and visually challenged or persons with limited English proficiency (LEP) will be made if NDOT is notified by October 14, 2020. Notification should be submitted to Sarah Soula (see contact information above).

This notice is provided pursuant to the Administrative Procedure Act.



RULE & REGULATION PRELIMINARY FISCAL IMPACT STATEMENT

AGENCY:	Nebraska Department of Transportation		
TITLE:	410	PREPARED BY:	Erich Strack
CHAPTER:	7	DATE PREPARED:	August 20, 2020
SUBJECT:	The Accommodation of Mailboxes and Newspaper Delivery Boxes and Support Posts on Highway Rights-Of-Way	TELEPHONE:	402-479-4324

TYPE OF FISCAL IMPACT:

	STATE AGENCY	POLITICAL SUBDIVISION	REGULATED PUBLIC
No Fiscal Impact	X	X	X
Increased Costs			
Decreased Costs			
Increased Revenue			
Decreased Revenue			
Indeterminable			

PROVIDE AN ESTIMATED COST AND DESCRIPTION OF IMPACT:

State Agency	
Political Subdivision	
Regulated Public	

IF INDETERMINABLE, EXPLAIN WHY:

~~TITLE 410, NEBRASKA ADMINISTRATIVE CODE, CHAPTER 7~~

~~NEBRASKA DEPARTMENT OF TRANSPORTATION
RIGHT OF WAY DIVISION~~

~~RULES AND REGULATIONS CONCERNING
THE ACCOMMODATION OF MAILBOXES AND NEWSPAPER DELIVERY BOXES
AND SUPPORT POSTS ON HIGHWAY RIGHTS OF WAY~~

TITLE 410 – NEBRASKA DEPARTMENT OF TRANSPORTATION – RIGHT OF WAY DIVISION

Chapter 7 – The Accommodation of Mailboxes and Newspaper Delivery Boxes and Support Posts on Highway Rights-Of-Way

~~001 MAILBOXES, NEWSPAPER DELIVERY BOXES (HEREAFTER REFERRED TO AS MAILBOXES) LOCATED UPON STATE HIGHWAY RIGHT-OF-WAY THAT DO NOT CONFORM TO THE PROVISIONS OF THIS RULE AND REGULATION, MUST BE REMOVED FROM STATE HIGHWAY RIGHT-OF-WAY AS HEREINAFTER PROVIDED.~~

~~002 A MAILBOX AND SUPPORT POST THAT CONFORM TO THE CRITERIA HEREAFTER SET FORTH WILL BE CONSIDERED ACCEPTABLE, UNLESS IT INTERFERES WITH THE SAFETY OF THE TRAVELING PUBLIC OR THE FUNCTION, MAINTENANCE OR OPERATION OF THE HIGHWAY SYSTEM.~~

003 LOCATION

~~003.01 No mailbox will be permitted on the Nebraska Interstate System.~~

~~003.02 Mailboxes shall be located so that they are on the right hand side of the roadway as determined by the direction of travel as designated by the local postmaster for each delivery route. On one-way streets, mailboxes may be on the left side if designated by the local postmaster.~~

~~003.04 Mailboxes shall be located outside the shoulder line on roadways without curbs so that the roadside face of the mailbox does not extend beyond the shoulder line of the highway.~~

~~003.05 Mailboxes shall be located back of the curb on roadways with curbs so that the roadside face of the mailbox does not extend beyond the back of the curb line of the highway.~~

~~003.06 The mailbox supports shall be no closer than one foot outside the shoulder line or back of the curb line on any highway.~~

~~003.07 Where a mailbox is located at a driveway, it shall be placed on the far side of the driveway as determined by the direction of travel designated by the local postmaster for each delivery route.~~

004 STRUCTURE

~~004.01 Mailboxes shall be of light sheet metal or plastic construction, conforming to the requirements of United States Postal Service Standard No. 7, whose requirements are attached to and made part of this rule and regulation as Exhibit 2. Newspaper delivery boxes shall be of sheet metal, or plastic construction of a minimum dimension suitable for holding a newspaper.~~

~~004.02 No more than two mailboxes may be mounted on a support structure, unless the support structure mailbox arrangement have been shown to be safe by crash tests conducted by the Texas Transportation Institute, the Southwest Research Institute, or the~~

TITLE 410 – NEBRASKA DEPARTMENT OF TRANSPORTATION – RIGHT OF WAY DIVISION

Chapter 7 – The Accommodation of Mailboxes and Newspaper Delivery Boxes and Support Posts on Highway Rights-Of-Way (Continued)

~~University of Nebraska College of Civil Engineering. However, newspaper boxes may be mounted below the mailbox on the side of the mailbox support. The front of the newspaper box shall not extend beyond the front of the mailbox.~~

~~004.03 Mailbox supports shall not be set in concrete.~~

~~004.04 Mailboxes must be mounted upon a breakaway post conforming to the following:~~

~~004.04A A breakaway 2-piece post, with a weight no greater than two pounds per foot and embedded no more than 3 feet 6 inches into the ground will be acceptable as a mailbox support.~~

~~004.04B Breakaway mailbox support posts shall conform to the design shown on Exhibits 1A and 1B attached hereto, except such support posts which have been tested by the Texas Transportation Institute, the Southwest Research Institute, or the University of Nebraska College of Civil Engineering and are certified by that authority to be breakaway posts shall be acceptable as mailbox supports.~~

~~004.05 The post to box attachment shall conform to the requirements of Exhibits 1A and 1B or those tested and approved by the Texas Transportation Institute, the Southwest Research Institute, or the University of Nebraska College of Civil Engineering.~~

~~004.06 Conforming metal posts and attachments will be available at the Nebraska Department of Transportation's Maintenance Office at no cost to the mailbox owner.~~

~~004.07 When multiple mailbox supports are required, the minimum spacing between the center of the mailbox supports shall be 36 inches.~~

~~**005 REMOVAL OF NONCONFORMING OR UNSAFE MAILBOXES AND SUPPORT POSTS**~~

~~005.01 Nonconforming mailboxes located on highways being reconstructed by the Nebraska Department of Transportation, or located within areas designated as "Mailbox Safety Project Areas" by the Nebraska Department of Transportation, must be removed. Upon the removal of such mailboxes, the Nebraska Department of Transportation, at its expense, will provide and install mailbox supports and attachments that conform to the requirements of this rule and regulation. Mailboxes will not be provided by the Nebraska Department of Transportation.~~

~~005.02 **NOTICE:** Mailbox owners and the local postmaster will be notified 20 days in advance of the date that existing mailboxes must be removed. Mailboxes not removed within the 20-day notice period will be removed and disposed of by the Nebraska Department of Transportation.~~

**TITLE 410 – NEBRASKA DEPARTMENT OF TRANSPORTATION – RIGHT OF WAY
DIVISION**

**Chapter 7 – The Accommodation of Mailboxes and Newspaper Delivery Boxes and
Support Posts on Highway Rights-Of-Way (Continued)**

~~**006 MAINTENANCE OF MAILBOXES INSTALLED PURSUANT TO THIS RULE AND
REGULATION**~~

~~**006.01** The mailbox owner shall bear the cost of maintaining his/her mailbox and the department's mailbox support. Repair parts for the safety mailbox support may be obtained from the Nebraska Department of Transportation's Maintenance Office at no cost to the mailbox owner.~~

~~**006.02** Mailbox owners with mailboxes located on the State Highway System wishing to install the Nebraska Department of Transportation safety mailbox support prior to either a highway construction project or a mailbox safety project, may obtain a mailbox support at the Department of Transportation's Maintenance Superintendent Headquarters at no cost. Recipients of such mailbox supports must sign a certificate stating that the support will be installed on the State Highway System pursuant to these Rules and Regulations.~~

~~**006.03** Mailbox owners wishing to locate mailboxes on State Highway Right-Of-Way in areas in which mailboxes have been replaced pursuant to Section 005.01, may obtain a mailbox support at the Department of Transportation's Maintenance Office at no cost. The cost of The mailbox will be borne by the mailbox owner.~~

ANNOTATION

~~**Title 410
Chapter 7**~~

~~**Enabling Legislation
§39-699
Neb. Rev. Stat.**~~

**TITLE 410 – NEBRASKA DEPARTMENT OF TRANSPORTATION – RIGHT OF WAY
DIVISION**

**Chapter 7 – The Accommodation of Mailboxes and Newspaper Delivery Boxes and
Support Posts on Highway Rights-Of-Way (Continued)**

Exhibit 1A

TITLE 410 – NEBRASKA DEPARTMENT OF TRANSPORTATION – RIGHT OF WAY DIVISION

Chapter 7 – The Accommodation of Mailboxes and Newspaper Delivery Boxes and Support Posts on Highway Rights-Of-Way (Continued)

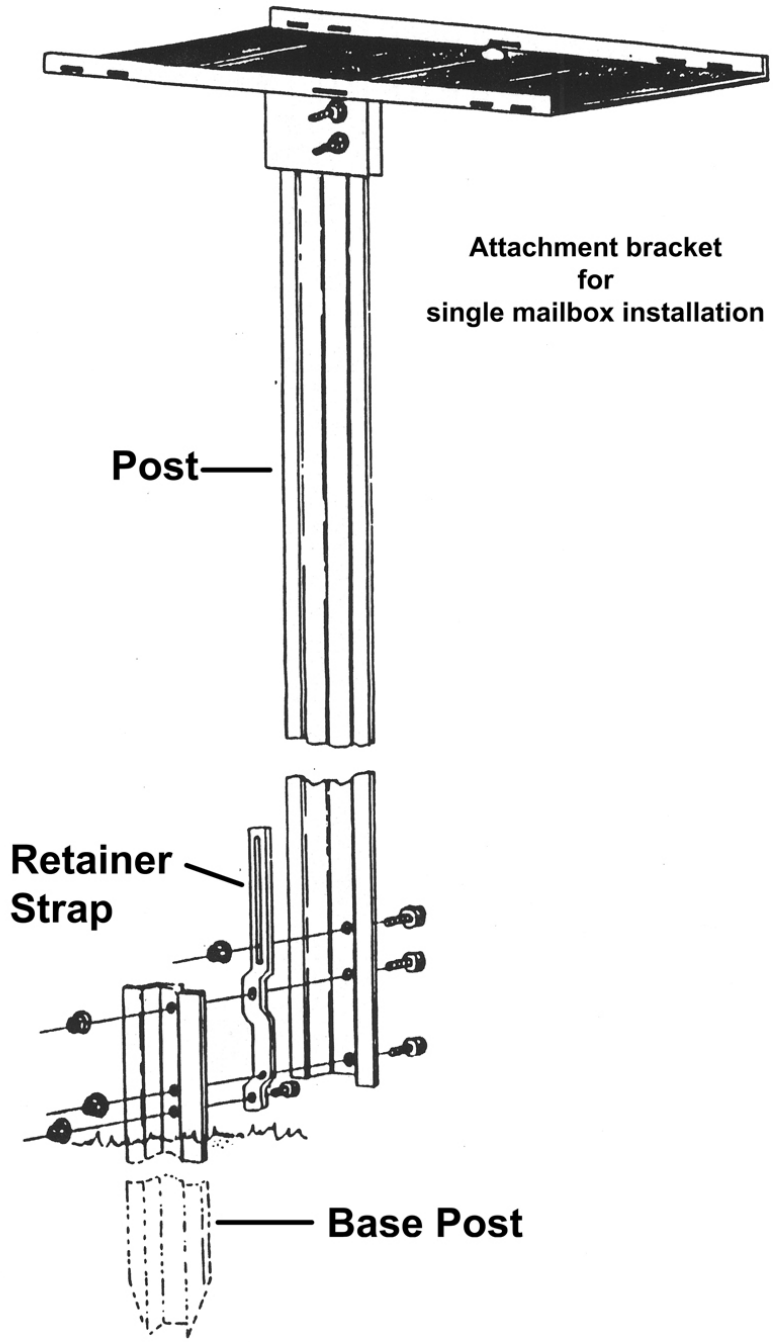

TITLE 410 – NEBRASKA DEPARTMENT OF TRANSPORTATION – RIGHT OF WAY DIVISION

Chapter 7 – The Accommodation of Mailboxes and Newspaper Delivery Boxes and Support Posts on Highway Rights-Of-Way (Continued)

